

Concrete Transportation

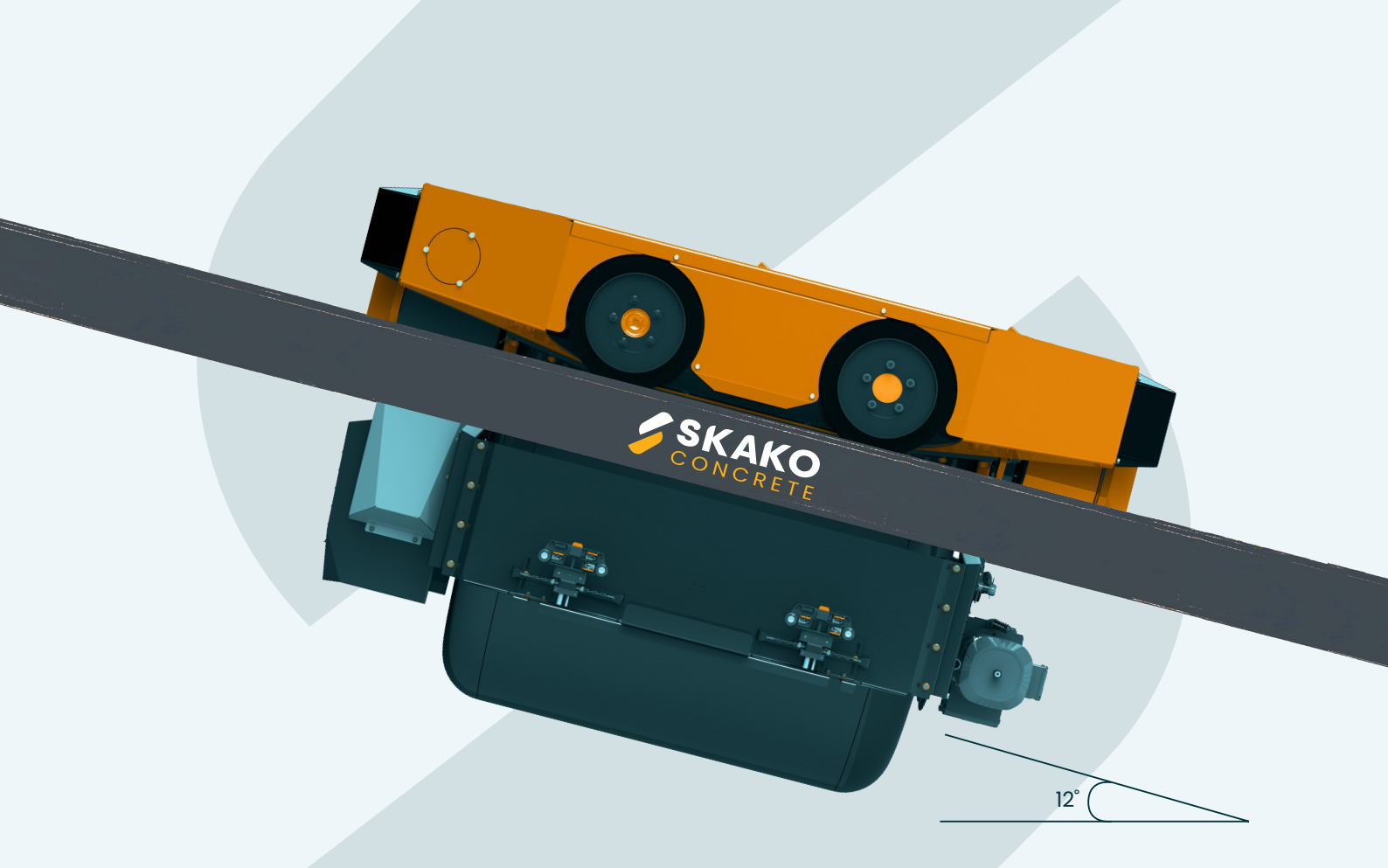



CONFLEX – Transportation of concrete in bucket conveyors...

High safety factor
Flexible
Low noise

The entire rail layout is entered into the SKAKOFLEX control and software and makes it possible to adapt the speed and approach the movable station correctly.

100% controlled by the SKAKOFLEX software and wireless touch panels as option.

Combines more mixing plants with multiple work stations.

High speed – up to Up to 16.4 ft/s
Inclines up to 12°
Discharge system for SCC concrete

The control system controls up to 10 buckets, 32 work stations and 8 mixers.

Fully automatic operation to both fixed and movable stations.

The Conflex bucket conveyors are available in three sizes. You can choose between rotating discharge, bottom discharge (crosswise), and bottom

discharge (lengthwise). The bucket conveyors with bottom discharge have a completely sealed closure system.

Bucket conveyors with two-compartment hoppers to separate two kinds of concrete are also available.

CONFLEX COMPLEX RAIL SYSTEMS, LONG DISTANCES, MORE BUCKETS AND INCLINATIONS
CONFLEX ECO COST EFFICIENT FOR SHORT TRAVEL DISTANCES

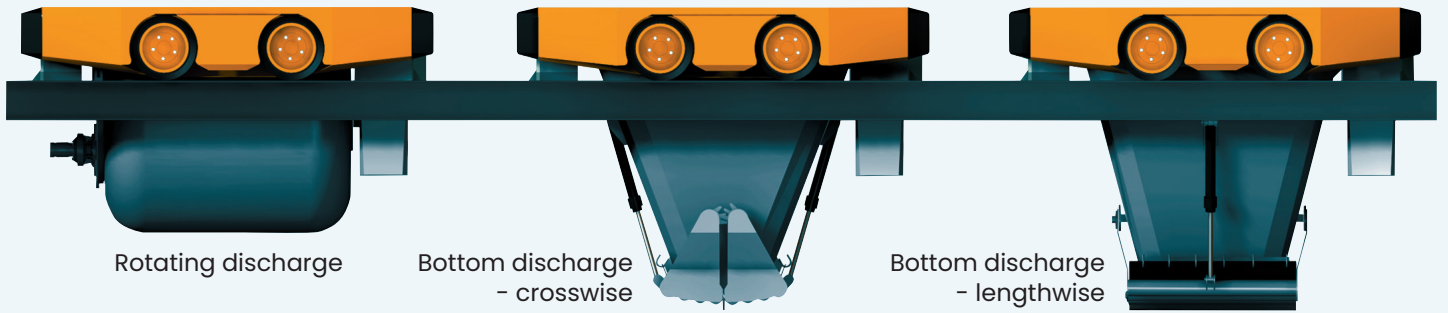

	CONFLEX 1500	CONFLEX 3000	CONFLEX 3750
Speed Feet/Sec. ∞)	Up to 16.4	Up to 16.4	Up to 16.4
Curves	Yes	Yes	Yes
Inclines	Yes	Yes	Yes
Power	Hydraulic	Hydraulic	Hydraulic
Drive	4 x 4	4 x 4	4 x 4

∞) Speeds indicated refer to speed on the entire track on horizontal sections

Washing System for Conflex

Automatic high-pressure washing system suspended in the travel rail consisting of a collecting funnel with 4 m rubber draining hose as well as a compressed-air cylinder with rotating washing head. Pump operates at 2,500 psi with a flow at 20 GAL/min which results in a close to 100% clean inside of the bucket in only a few minutes.



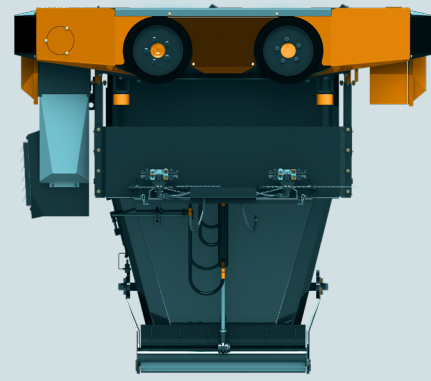
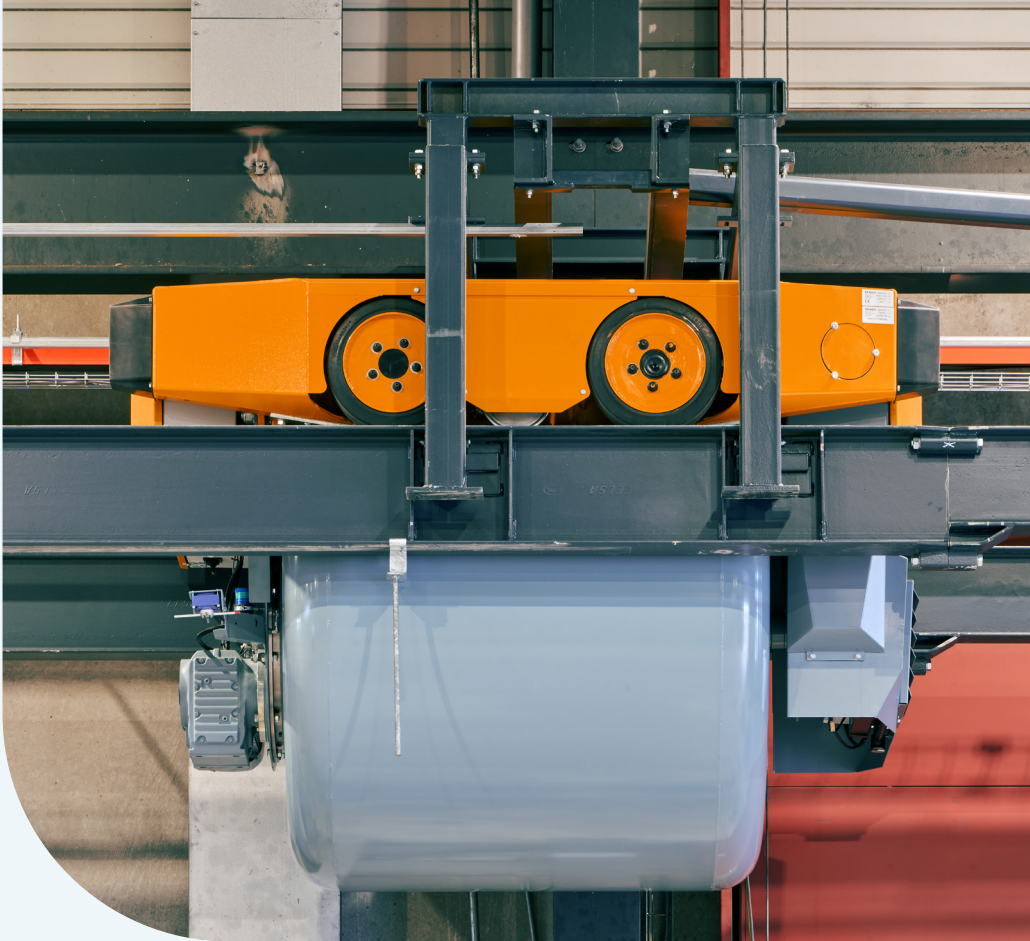

SKAKO Concrete distribetron

CONCRETE DISTRIBUTION SYSTEM FOR MOULDS AND CASTING MACHINES

- SKAKO Concrete distribetron transports fresh concrete from conveyor bucket to any point of usage in factory hall
- Movable or fixed stations
- Fully or semi-automatic ordering system via touch panel or tablet
- Two types of bottom discharge
- Order box or via tablet/smartphone
- Full integration of concrete mixing / batching and distribution system



- Hydraulically operated gate
- Bottom discharge gate for all types of concrete
- Single discharge for SCC concrete
- Double discharge for dry concrete
- Portal or semi-portal design
- Up to 26 m span
- Dumping or controlled discharge of concrete
- High-pressure cleaning



www.skakoconcrete.com