



# Products & Solutions





# What makes the Alpha mixer so much better?

If you need a reliable, durable, safe, and quick quality concrete mixer with a long operating life that is easy to use and maintain; our newest concrete mixer – the Alpha Mixer – is the right choice. The Alpha Mixer is a counter-current concrete mixer for production of high and low slump as well as SCC concrete.



## Fully electric

Controlled by a hybrid belt/chain gear system, meaning that the mixer hardly uses any oil.



## Transport friendly

Can be shipped as standard load in three parts. No need for special transportation.



## Automatic cleaning

High-pressure system removes the need for manual cleaning inside the mixer.



## Inspection hatch

Top hatch for safe monitoring of the mixing process, with optional LED light.



## Sampler

Semi-auto, electro-hydraulic sampler for safe, easy concrete sample extraction.



## Safety system

Key-interlocked door safety exceeds EU quality and performance standards.

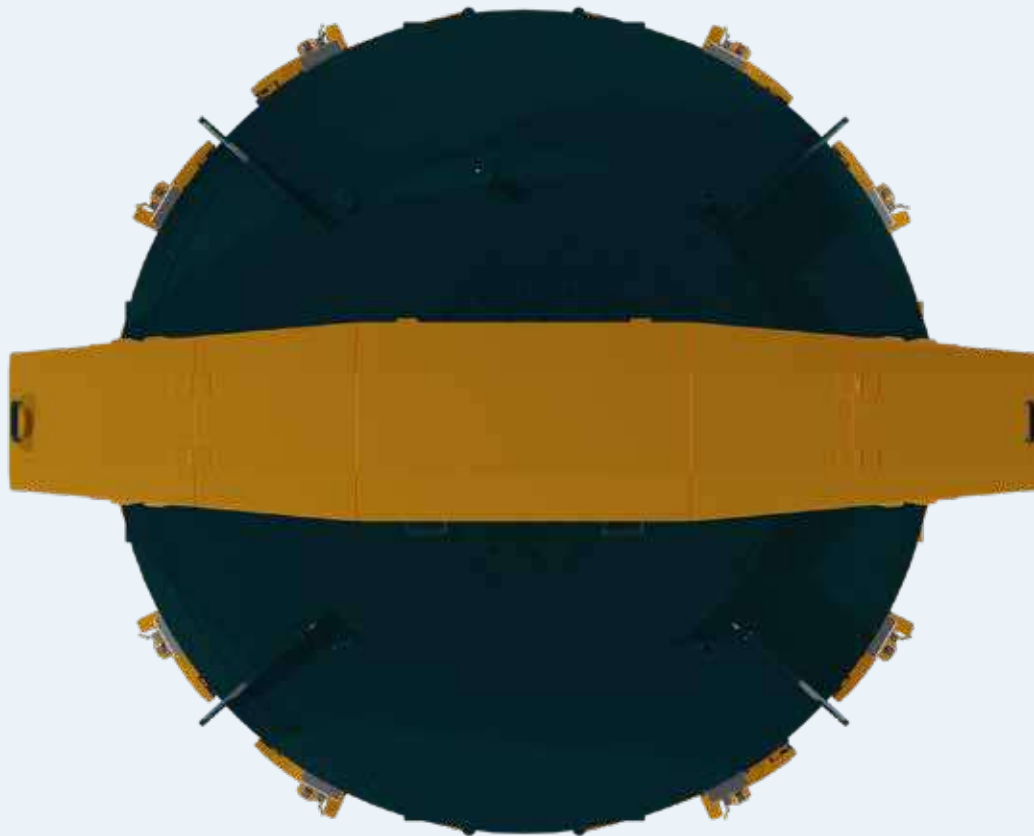

## Other highlights

### Less Noise

Makes less noise due to the new evolutionary design of the mixer.

### Low build height

The mixer is lower, making it easy to fit into an existing production facility.

### Camera

Optional remote camera surveillance monitors the mixing process from the control room.

### Water proportioning

Device for adding water during production, with different models for various concrete types.

### Shovels

Unique two-level shovel technology ensures precise, high-intensity mixing. Bolts are countersunk to prevent concrete build-up.

### Manual operation

Mixing tools easily adjusted for optimal positioning during servicing.

### Moisture control

Electrodes measure concrete humidity, automatically regulating water addition via SKAKOMAT 600.

### Discharge gates

Detachable hatch with a safety system for easy cleaning and maintenance.

Type	750	1125	1500	2250	3000	3750
Volume yd <sup>3</sup> /lbs	1.0/2650	1.5/3970	2.0/5920	3.0/7940	4.0/10580	5.0/13230
Max. output per batch yd <sup>3</sup>	0.65	1.00	1.31	2.00	2.63	3.27
Motor size HP	25	40	2x30	2x40	2x50	3x40
Mixer stars	1	1	2	2	2	3

# Green Plant Vision

## SKAKO Concrete sustainability program

Two of the focus areas in our sustainability strategy, points at improving our own effort: One focus area is about optimizing our own production. Another focus area is about creating a work culture where it becomes usual practice to think profitable sustainability in everything we do.

Sustainability has been verbalized as a natural part of our everyday life. We have established sustainability groups and generally we focus on optimizing and improving where potentials are identified.



### Products

We aim at the lowest CO<sub>2</sub> impacting production of the industry: 70% CO<sub>2</sub> reduction before 2030 (index 1990)



### Circular

Our products must be reusable: Reuse > 95% before 2030



### Water

We will minimize the water consumption in concrete mixing: Reuse of water = 100% at the end of 2025.



### Cement

We want to produce concrete with the lowest possible cement content – without compromising with the strength in the concrete: 10% cement reduction by the end of 2025 (index 2010).

# Refurbish

## May we repurchase your old SKAKO Concrete product?

Do you have a used – but still useful – SKAKO Concrete product that you need to get rid of? Then, we might like to repurchase it in order to refurbish it and sell it to a new customer or to use the spare parts!

Depending on the model and the condition of your product, we are willing to repurchase:

- Bucket conveyors
- Concrete mixers
- Skip hoists

You are always welcome to contact us to get a quotation for your old SKAKO Concrete product.

## Do you want to buy a refurbished SKAKO Concrete product?

A refurbished SKAKO Concrete product is still a quality product. A concrete mixer, for instance, can easily last for 20–30 years if taken good care of. If you decide to buy a refurbished SKAKO Concrete product, we always provide you with a reasonable guarantee.

Besides contributing to a more sustainable world, another advantage of buying a refurbished product is the quicker delivery time. If we have the product you want in stock, it won't take very long to refurbish it and ship it to you.

Please contact us if you want to know what we have in stock.





# Atlantis Concrete mixer

The SKAKO Concrete Atlantis concrete mixer is a high performance planetary mixer, and the result of over 90 years of mixer evolution. Atlantis is designed to optimize mixing, cleaning, discharging, energy consumption, maintenance and safety in everyday use.



## Hydraulic powerpack

Manual discharge feature ensures power failure won't hinder discharge.



## Airbag

Anti-dust airbag system prevents the dust from entering the work environment



## Automatic cleaning

High-pressure system removes the need for manual cleaning inside the mixer.



## Inspection hatch

Top hatch for safe monitoring of the mixing process, with optional LED light.



## Sampler

Semi-auto, electro-hydraulic sampler for safe, easy concrete sample extraction.



## Safety system

Key-interlocked door safety exceeds EU quality and performance standards.

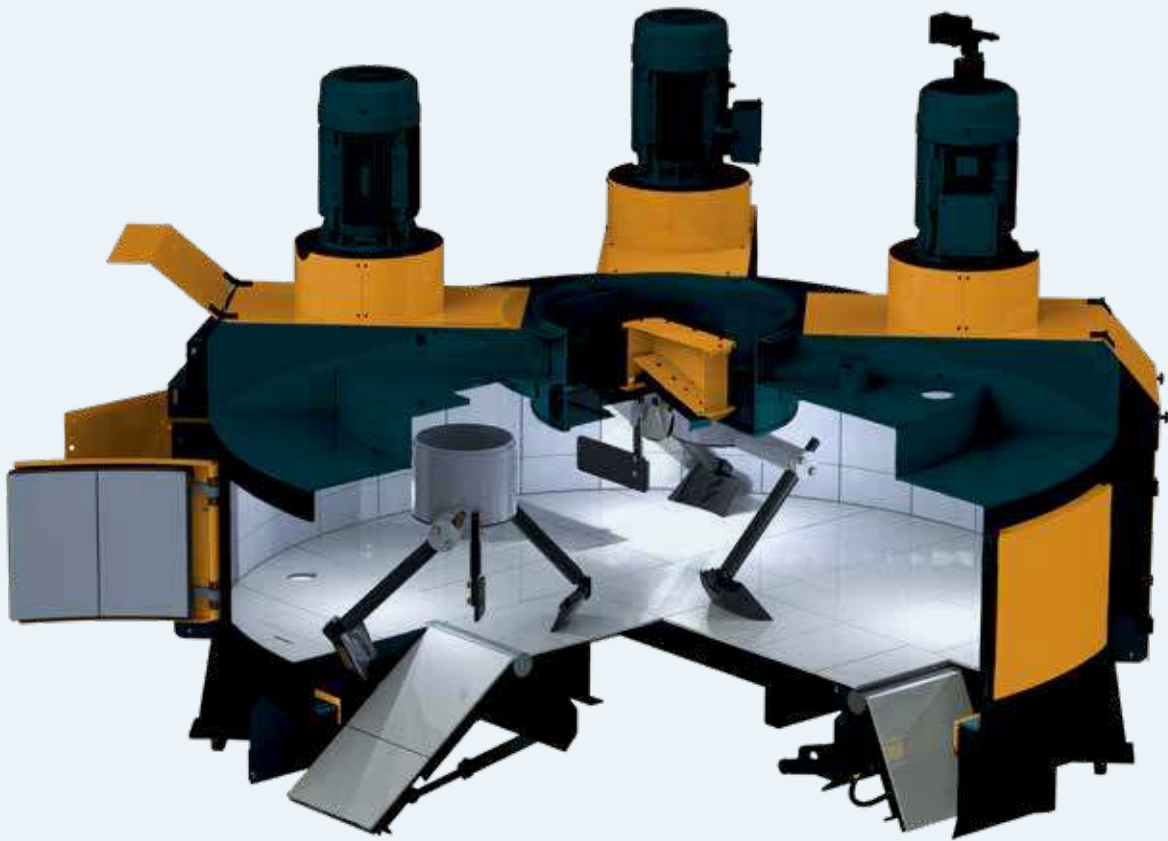

## Other highlights

### Camera

Optional remote camera surveillance monitors the mixing process from the control room.

### Inlet / skip hoist

Dustproof inlet for skip hoist bucket, closed when not in use. Large opening for quick material discharge.

### Water proportioning

Device for adding water during production, with different models for various concrete types.

### Shovels

Unique two-level shovel technology ensures precise, high-intensity mixing. Bolts are countersunk to prevent concrete build-up.

### Manual operation

Mixing tools easily adjusted for optimal positioning during servicing.

### Moisture control

Electrodes measure concrete humidity, automatically regulating water addition via SKAKOMAT 600.

### Discharge gates

Detachable hatch with a safety system for easy cleaning and maintenance.

Type	125	750	1125	1500	2250	3000	3750	4500	6000
Volume yd <sup>3</sup> /lbs	0.16/441	1.0/2650	1.5/3970	2.0/5290	3.0/7940	4.0/10580	5.0/13230	6.0/15870	8.0/21160
Max. output per batch yd <sup>3</sup>	0.10	0.65	1.0	1.31	2.0	2.63	3.27	4.0	5.23
Motor size HP	4	25	40	2x30	2x40	2x50	3x40	4x40	4x50
Mixer stars	1	1	1	2	2	2	3	3	4



# Rotoconix<sup>®</sup> is the ultimate response to your mixing needs

For very specific environments requiring ultra-high-performance concrete, mortars, or coloured concretes, in a wide range of batching sizes, the SKAKO Concrete Rotoconix mixer is the solution.



## Quick batching cycles

Efficient and rapid batching cycles optimize production time, enhancing overall workflow.



## Easy and fast discharge

Streamlined discharge process ensures quick and hassle-free material release.



## Smooth maintenance

Seamless and time-efficient maintenance guarantees uninterrupted operations.



## Flexible batch sizes

Versatile mixer allows variable batch sizes, reducing the need for additional investments.



## Stable quality at low cost

Consistently reliable quality, ensuring homogeneity, all at an affordable cost.



## Easy cleaning

Effortless cleaning options, streamline batch transitions for sustained efficiency.





## The Universal Triple Effect Concrete Mixer

Elevate your concrete mixing experience with Rotoconix, a cutting-edge solution that combines efficiency and quality seamlessly. Benefit from quick batching cycles, easy maintenance, and the

flexibility to produce various batch sizes from the same unit. Rotoconix is your key to streamlined operations, cost-effective homogeneity, and superior concrete quality.

Rotoconix®		375	750	1500	2250
Max. charging capacity / max. charging weight (*)	yd³/lbs	0.5/1325	1.0/2650	2.0/5290	3.0/7940
Output, compact concrete (*)	yd³	0.335	0.67	1.33	2.0
Min. batch volume	yd³/lbs	0.03	0.70	0.70	0.70
Motor power : pan rotation	HP	10	10	15	20
Motor power : screw	HP	10	15	30	40
Motor power : whirler	HP	15	20	40	50
Pan rotation speed range	HP	2-24	4-16	3.5-14.5	3.5-14.5
Screw rotation speed range	HP	10-120	25-100	18-72	15-60
Whirler rotation speed range	HP	30-300	75-300	50-200	40-160

\*Depending on mix design. Not all types of concrete can utilize the input/output volumes of the mixer. Testing up front is needed.

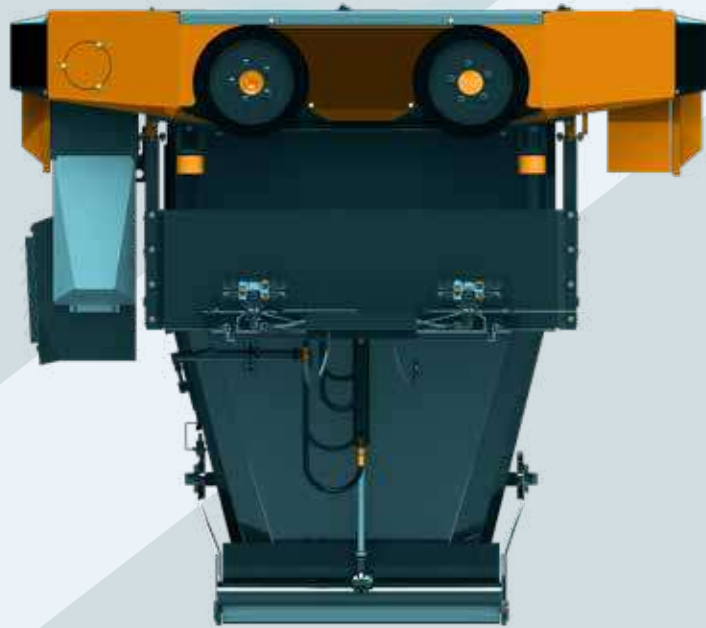

# SKAKO Concrete CONFLEX: An efficient bucket conveyor system

A swift conveyor system revolutionizing workflow at 5.0 m/s. Beyond speed, it optimizes workspace by reducing conveyors, ensuring a compact and efficient setup. SKAKO Concrete CONFLEX is your key to elevated material handling, simplifying processes for unmatched efficiency.



## High-Speed Transportation

SKAKO Concrete CONFLEX travels at 5.0 m/s, ensuring rapid bucket movement for efficient workflow.



## Space Efficiency

Maximize space and reducing conveyors needed for optimized efficiency.



## Low Noise Operation

Operates quietly, creating a focused workspace for enhanced productivity.



## Effortless Inclination

SKAKO Concrete CONFLEX inclines up to 12° for easy adaptation to different heights.



## Modular Design

Modular design for easy extension and configuration changes.



## Integrated Control System

Control up to 10 buckets, 32 work stations, and 8 mixers seamlessly.



## Available in three sizes

CONFLEX is available in three sizes each of them with rotating and bottom discharge – the bottom one with completely sealed closure system.

Possibly even buckets with a two compartment hopper to separate two kinds of concrete.

The control system controls up to 10 buckets, 32 work stations and 8 mixers.



	CONFLEX 1500	CONFLEX 3000	CONFLEX 3750
Speed Feet/Sec. ∞)	Up to 16.4	Up to 16.4	Up to 16.4
Curves	Yes	Yes	Yes
Inclines	Yes	Yes	Yes
Power	Hydraulic	Hydraulic	Hydraulic
Drive	4 x 4	4 x 4	4 x 4

∞) Speeds indicated refer to speed on the entire track on horizontal sections



# SKAKO Concrete DISTRIBETON

Get your concrete from mixing to casting with Distribetron:  
Our concrete distribution system for moulds and casting machines.



## Efficient Concrete Distribution

Transports fresh concrete efficiently from conveyor buckets to any point in the factory hall.



## Flexible Station Options

Choose between movable or fixed stations for versatile concrete distribution.



## Intuitive Ordering System

Fully or semi-automatic ordering system via touch panel or tablet, ensuring user-friendly operation.



## Controlled Discharge Options

Choose between dumping or controlled discharge of concrete, ensuring precision in distribution.



## Diverse Design Configurations

Portal or semi-portal design with up to a 85 ft span, offering various configurations.

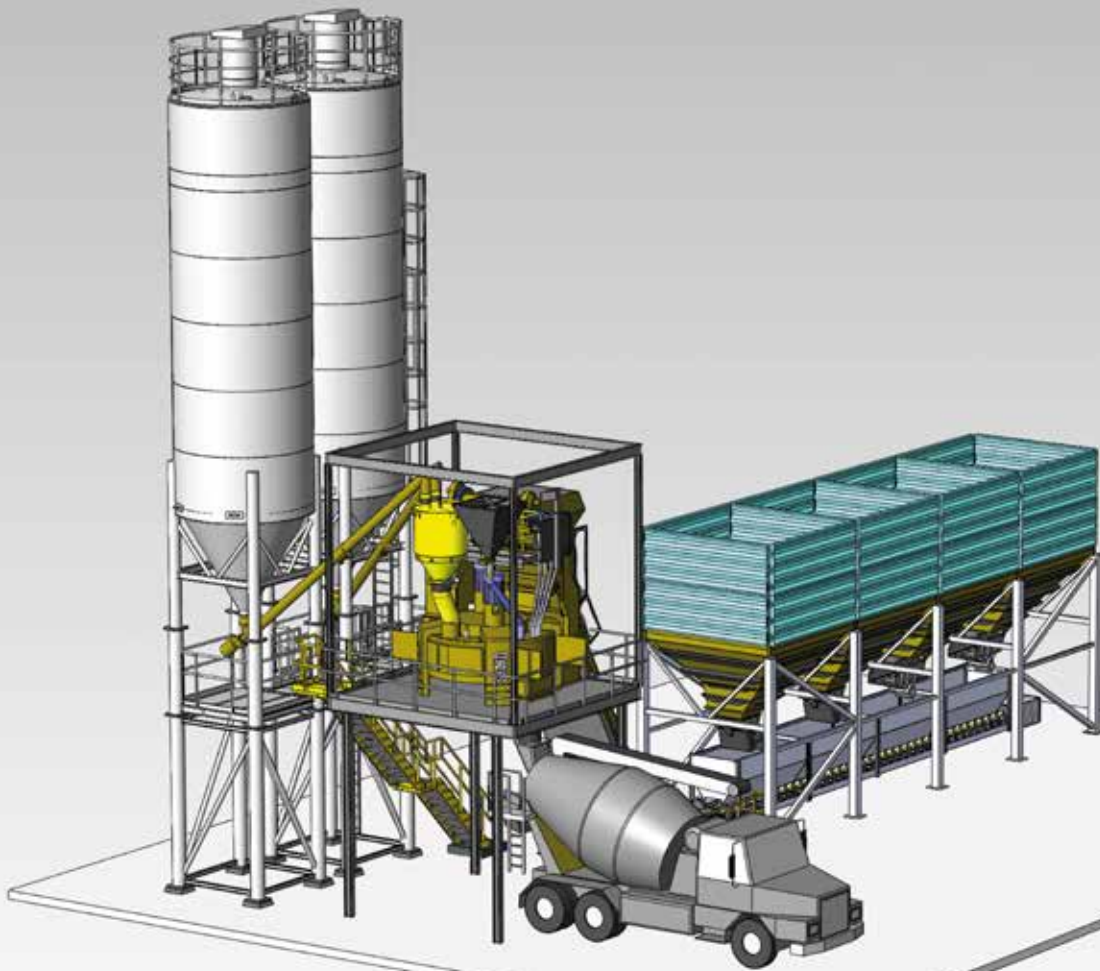

# Row Silo Plants

The modular design meets all your needs for an unlimited number of rows and compartments



## Modular Design

Tailor the system to your specific needs with optimal customization opportunities.



## Surface Treatment Options

Choose between painted or galvanized surfaces for durability and aesthetics.



## Easy Assembly

Walls are easy to assemble with trapezoidal profiles, ensuring a streamlined process.



## Accessible Silo Design

Ensure easy access to the silo through a manhole, facilitating maintenance tasks.



## Diverse Equipment Options

A diverse range of equipment, including heating options and shock blasters for the silo cone.



# High Silo Plants

The best possible utilization of the production area, high capacity – small footprint



## High Capacity Storage

Achieve up to 1200 m<sup>3</sup> storage with an eco-friendly design, optimizing resource utilization.



## Efficient Power Usage

Reduce power consumption with short-distance material transport, for energy efficiency.



## Low Maintenance

Minimize maintenance costs with fewer moving parts, ensuring seamless operation.



## Modular Design

Our modular design offers tailored solutions, ensuring a perfect fit for your needs.



## Diverse Equipment Options

Extra equipment like stairs platforms and ladders for operational flexibility.



## Frost-Free Storage – Option

Frost-free storage in heated silo compartments for optimal material integrity.



# High Row Silo

Combining the best of two worlds - the high silo and row silo solutions



## Quick Setup

Fast installation with pre-cabled and pretested components, reducing engineering efforts.



## Easy Removal

Effortlessly removable and transportable design, allowing flexibility for relocation.



## Modular Design

Modular setup with 4-8 compartments, offering flexible layouts.



## Safety-Focused Design

Secure railing, anti-slip landing, and floor-level access for safety



## Maintenance Access

Easy access for cleaning/inspection, bracket to lift up spares.



## Automated Production

Automated features for optimized production, reducing manual interventions.

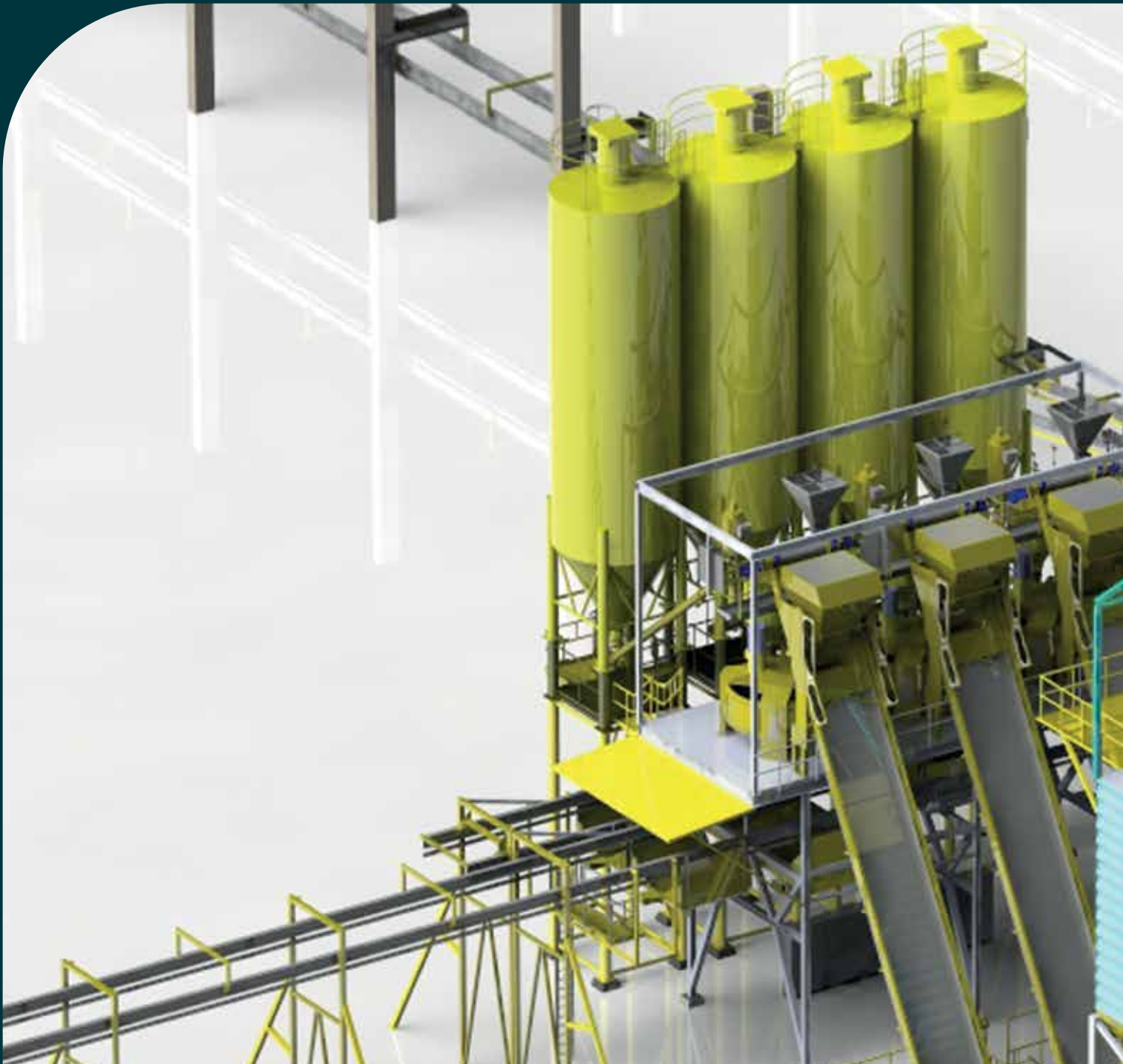

# Analyze your needs for concrete production

SKAKO Concrete is a professional and experienced group specialized in development, supply, installation and servicing of complete plants for production of concrete.

SKAKO Concrete's main purpose is to develop solutions adapted to future requirements, meeting the individual needs of our customers and so helping

them strengthening their position in their market. We offer knowledge, experience, flexibility and understanding of your situation. Basis of this are mutual discussions and co-operation.

Get in contact and let us design and propose your future reliable, functional, rational, compact, safe and energy-saving plant!



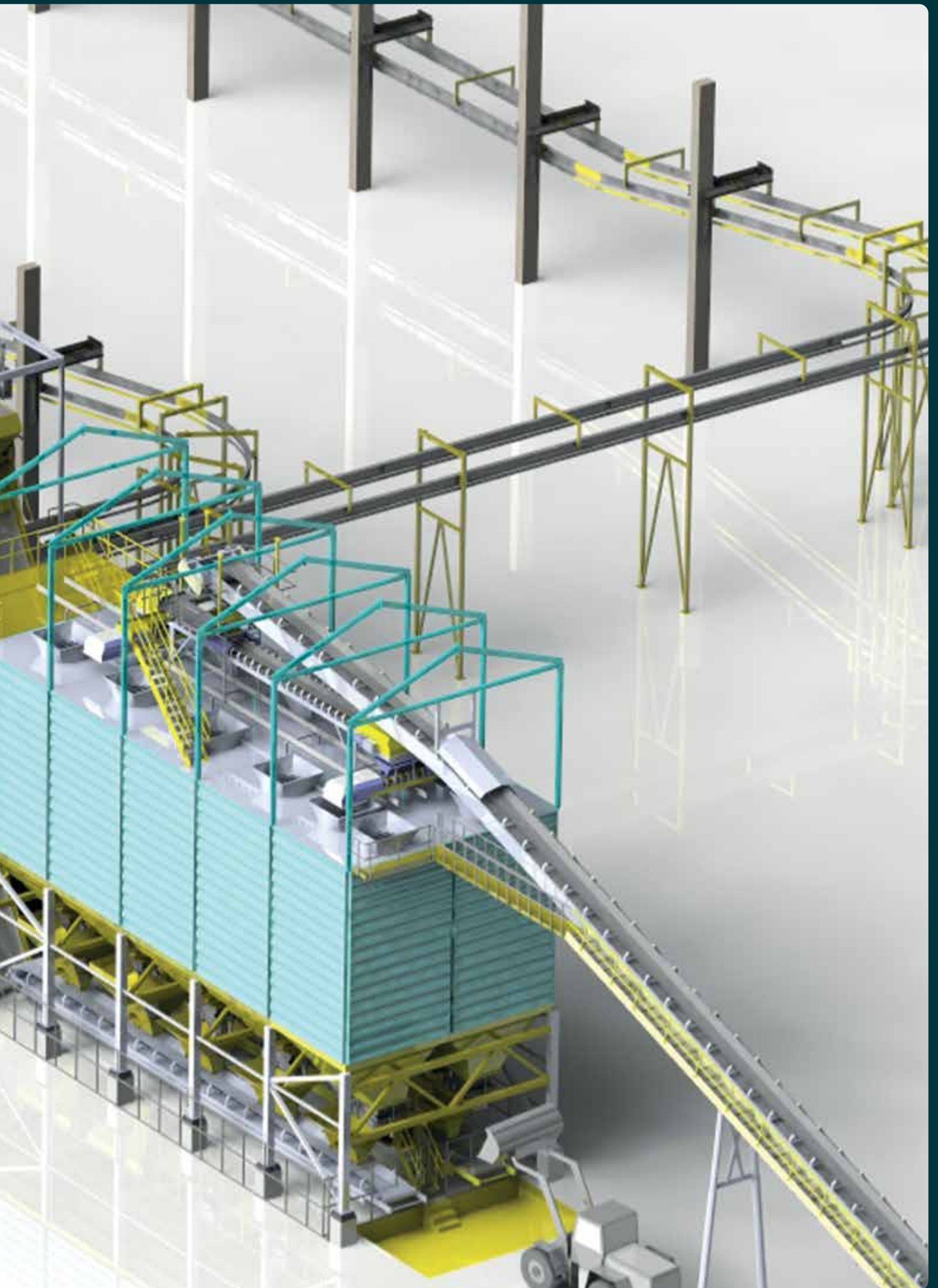



# SKAKOMAT 600S – 600 SQL

Introducing SKAKOMAT 600 SQL, the forefront of automation for concrete batching plants. Operating on the robust Windows 10 platform and featuring Soft PLC technology, this control system is a testament to SKAKO Concrete's commitment to excellence in automation.



## Increased Productivity

Boosts efficiency, elevating overall productivity for your concrete batching plant.



## Improved Profitability

Streamlined processes and optimized resource use contribute to increased profit.



## Optimized Logistics

Seamless operations within your batching plant with precision in logistics management.



## Enhanced Quality Control

Advanced quality control measures for consistent, superior concrete production.



## Mobile Access To Data

New mobile app gives access to cloud-based production data.



## Reduced Manpower

Automation reduces the need for manual intervention, saving on manpower costs.

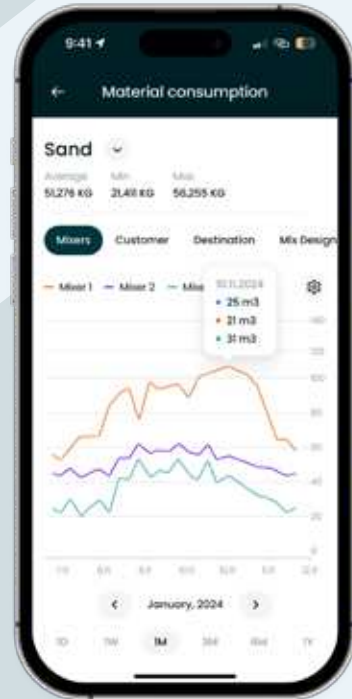

# Fully automated with SKAKO Concrete control system

SKAKO Concrete's control system ensures precise mixing for quality results.



## Integrated Automation

Streamline processes with SKAKO Concrete's automation, ensuring productivity and consistency.



## Efficiency Boosting

Calculate key figures fast, increasing equipment efficiency for productivity.



## Versatile Concrete Delivery

Deliver concrete to various equipment. Unlimited mix designs for flexibility.



## Control and Monitoring

Control plants with ERP interface, ensuring precise batch control and consistency.



## Data Management

Manage moisture levels actively, ensuring security for quality control.



# Service & support

## SKAKO Concrete original spare parts assistance

We understand the importance of fast and reliable spare parts service. Our extensive inventory of original spare parts, together with our staff of experienced experts, is your guarantee that we can deliver on this promise.

You can conveniently reach SKAKO Concrete for spare parts service by phone or mail. Always insist on original SKAKO Concrete spare parts for guaranteed quality and performance.

Visit our webshop here:  
[webshop.skakoconcrete.com/en/](http://webshop.skakoconcrete.com/en/)

## On-demand technical support

SKAKO Concrete customers can always choose to purchase the services and support they need on-demand.

- Plant performance
  - Plant review
  - Plant optimization
- Three-level service contracts
- Onsite service
- Onsite repair
- Calibration
- Own repair workshop
- Software backup and updates
- Telephone and online support



[www.skakoconcrete.com](http://www.skakoconcrete.com)

### OFFICE HOURS

Monday–Thursday: 07:30 – 15:30 CET

Friday: 07:30 – 15:00 CET

Tel.: +45 6361 6100

[sparepart@skakoconcrete.com](mailto:sparepart@skakoconcrete.com)

### Hotline

Monday–Friday: 06:00 – 19:00 CET

Saturday–Sunday: Closed

Tel.: +45 7026 2645

[support@skakoconcrete.com](mailto:support@skakoconcrete.com)